

**WILDEN'S DRUM PUMP KIT**

# **A BETTER WAY TO PUMP**



- SELF-PRIMING
- 8.6 BAR (125 PSIG) MAX
- ON/OFF RELIABLE
- INTRINSICALLY SAFE
- ABILITY TO RUN DRY
- ABILITY TO DEADHEAD

**WILDEN**<sup>®</sup>

A **DOVER** COMPANY

# ENGINEERED REVOLUTION

## Universal Drum Pump Kit

(One kit fits both 6 mm (¼") & 13 mm (½") Wilden Pumps)

### Drum Pump Kit Options:

Description	Part No.	Ship Weight	Box Dimension
Universal Drum Pump Kit-Polypropylene	50-9290-20	1.4 kg (3 lbs)	3'x6"x4"
Universal Drum Pump Kit-Teflon PTFE	50-9290-55	1.4 kg (3 lbs)	3'x6"x4"
Universal Drum Pump Kit-Nylon	50-9290-23	1.4 kg (3 lbs)	3'x6"x4"

A.025 & P.025 Installation

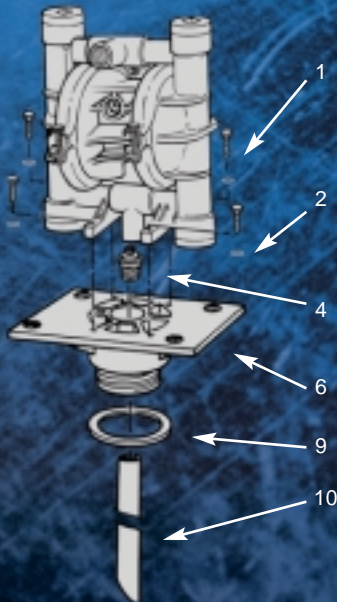

P100 Advanced™ Installation

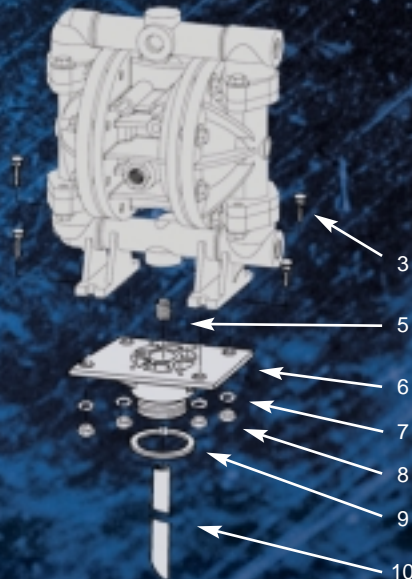

A1, P1 & T1 Installation

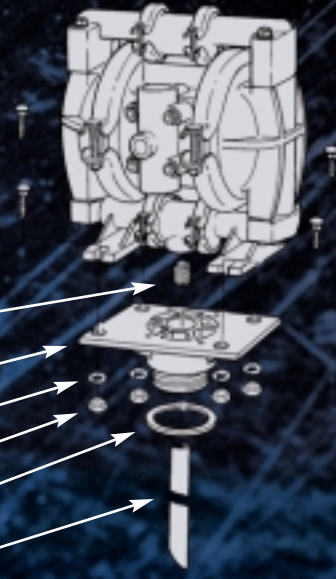

# WILDEN®

A DOVER COMPANY

### Drum Pump Parts:

Item#	Qty	Description	Part No.	Material of Construction
1	4	Self Tapping Screws	50-6350-03	Stainless Steel
2	4	Flat Washer	00-6740-03-514	Stainless Steel
3	4	Carriage Bolt ¼ - 20x1½	02-6050-03-500	Stainless Steel
4	1	Adapter Nipple for P.025 & A.025	50-9360-20	Polypropylene
			50-9360-23	Nylon
			50-9360-55	Teflon® PTFE
5	1	Adapter Nipple for T1, A1 & P1	50-9350-23	Nylon
			50-9350-55	Teflon® PTFE
6	1	Drum Pump Base Adapter	50-9330-20	Polypropylene
			50-9330-23	Nylon
7	4	Lock Washer	50-6760-03	Stainless Steel
8	4	¼ - 20 Nut	04-6400-03	Stainless Steel
9	1	Drum Pump Base Gasket	50-1480-52	Buna-N
10	1	Pick-up Tube	50-9310-20	Polypropylene
			50-9310-23	Nylon
			50-9310-55	Teflon® PTFE

22069 Van Buren St., Grand Terrace, CA 92313-5607  
 Telephone (909) 422-1730 • Fax (909) 783-3440  
 wilden@wildenpump.com

Your local authorized distributor:

**G&W Industrial Sales**

915 Emerson Avenue  
 Parkersburg, WV 26104  
 304-422-4755

[mail@gwindustrial.com](mailto:mail@gwindustrial.com)

