

ID & IP Series

IN-LINE DISC & PISTON VALVES



 *Strahman*

PROCESS VALVES

IN-LINE DISC & PISTON VALVES

Code: **IPYM**

M Seal In-Line Piston Valve

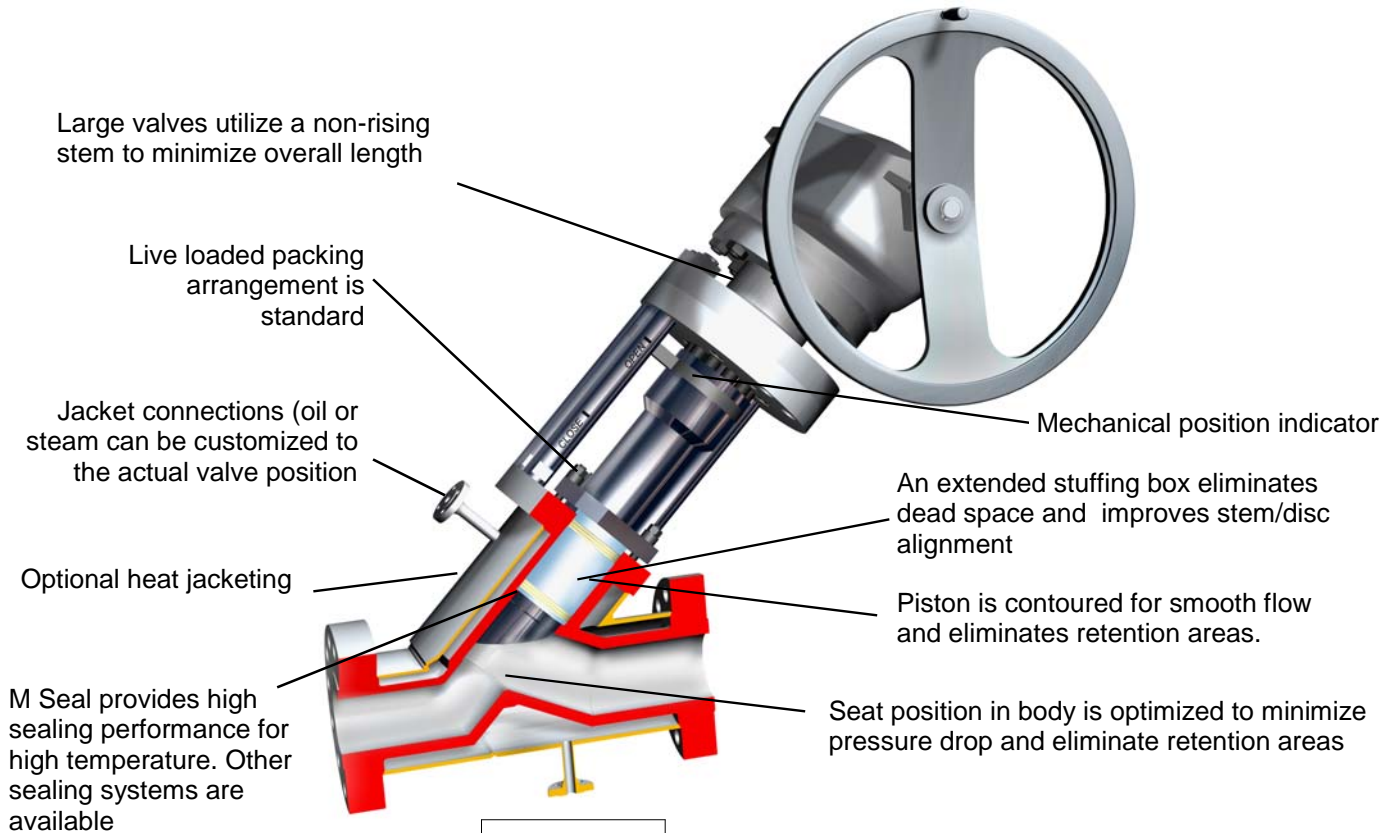

Fig. 038D

Code: **IDYM**

In-Line Disc Valve

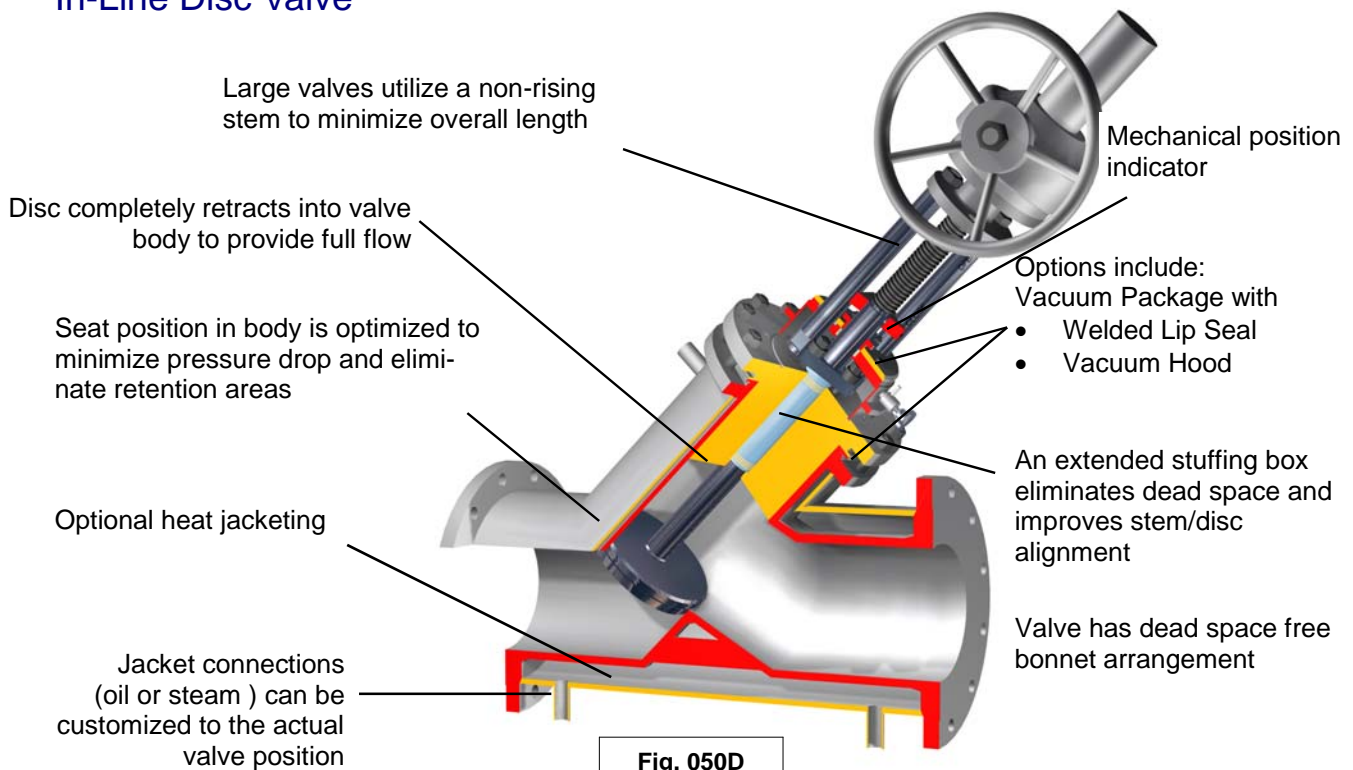

Fig. 050D

As an alternative to a failing ball, plug or gate valve, Strahman offers in-line disc and piston valves. With a wide range of positive sealing systems like M Seal, M Ring Seal and M Control, these valves provide superior in-line tightness. When opening the piston or disc it retracts completely into the valve body providing an unrestricted full flow. In combination with our maximized port sizes, these designs offer maximum flow capacity. They are available in a wide choice of options including materials of construction, sealing systems to atmosphere, actuators, full jacketing and a vacuum package.

Typical applications for in-line piston valves is to provide a dead space free valve for high viscosity products or abrasive slurries, especially in combination with high pressures and high temperatures.

BODY ARRANGEMENTS

Strahman In-Line valves has several styles available:

- Figure **037** for small sizes Y pattern piston valves with a rising stem design
- Figure **038** for large sizes Y pattern piston valves with a non-rising stems
- Figure **050** for Y pattern disc valves with rising or non-rising stem
- Figure **055** for angle pattern disc valves with rising or non-rising stem

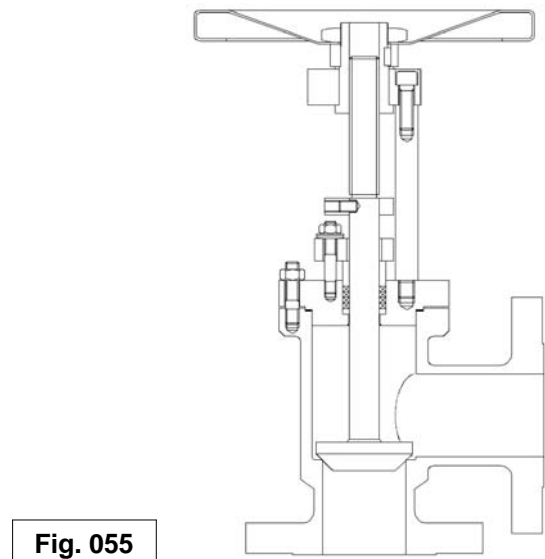
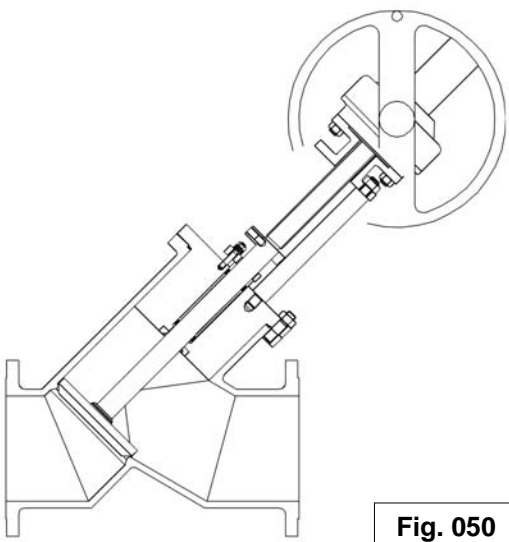
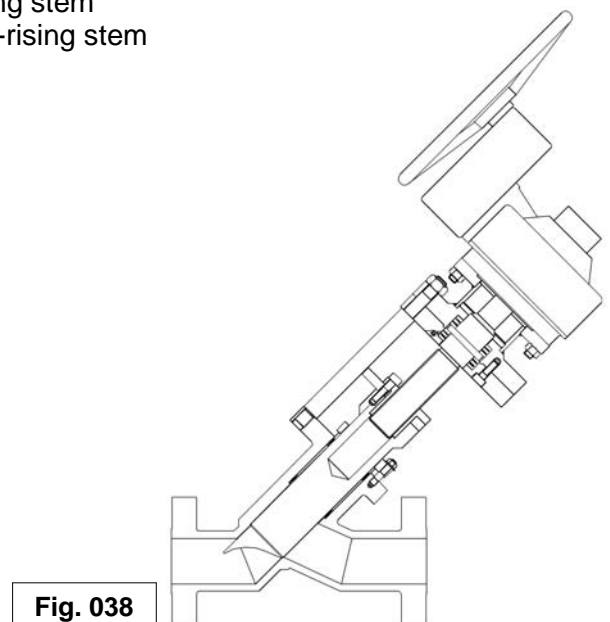
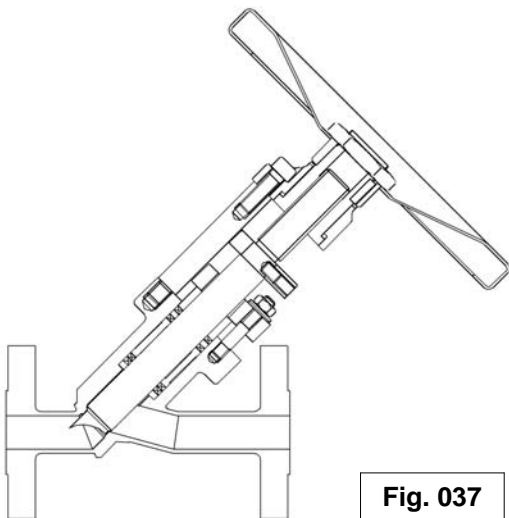

ADDITIONAL DRAIN OR INJECTION VALVE

In some processes, an additional valve can be required to serve as a drain valve for the product line (dump valve) or to inject additives. This additional valve can be welded to the body of the main valve as shown in this example.

Additional valve

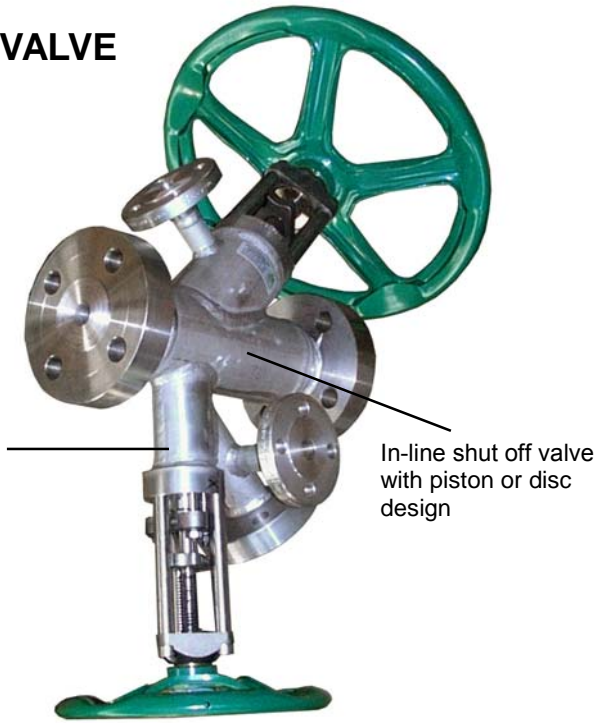

In-line shut off valve with piston or disc design

RANGE DEFINITION

ID Manufacturing Range	Manufacturing Range												
	PN 10	PN 16	PN 20-150 lbs.	PN 25	PN 40	PN 50 300 lbs.	PN 64 400 lbs.	PN 100 600 lbs.	PN 150/160-900 lb	PN 250 -1500 lb	PN 320	PN 420-2500 lb	PN 630 -4500 lb
3/8"- DIN10													
1/2"- DIN15													
3/4"- DIN20													
1"- DIN25													
1 1/4"- DIN32													
1 1/2"- DIN40													
2"- DIN50													
2 1/2"- DIN65													
3"- DIN80													
4"- DIN100													
5"- DIN125													
6"- DIN150													
8"- DIN200													
10"- DIN250													
12"- DIN300													
14"- DIN350													
16"- DIN400													
18"- DIN450													
20"- DIN500													
24"- DIN600													
28"- DIN700													
32"- DN800													
36"- DN900													
40"- DN1000													
44"- DN1100													
48"- DN1200													

ID Manufacturing Range	Manufacturing Range												
	PN 10	PN 16	PN 20-150 lbs.	PN 25	PN 40	PN 50 300 lbs.	PN 64 400 lbs.	PN 100	PN 150/160 -	PN 250 -1500 lb	PN 320	PN 420-2500 lb	PN 630 -4500 lb
3/8"- DIN10													
1/2"- DIN15													
3/4"- DIN20													
1"- DIN25													
1 1/4"- DIN32													
1 1/2"- DIN40													
2"- DIN50													
2 1/2"- DIN65													
3"- DIN80													
4"- DIN100													
5"- DIN125													
6"- DIN150													
8"- DIN200													
10"- DIN250													
12"- DIN300													
14"- DIN350													
16"- DIN400													
18"- DIN450													
20"- DIN500													
24"- DIN600													

SEALING SYSTEMS PISTON VALVES

M Seal- This sealing system offers a wide range of material combinations selected to create a differential hardness between body and plunger seat. The maintenance friendly design of the **M Seal** system provides long & reliable valve performance and is suitable for almost all process conditions.

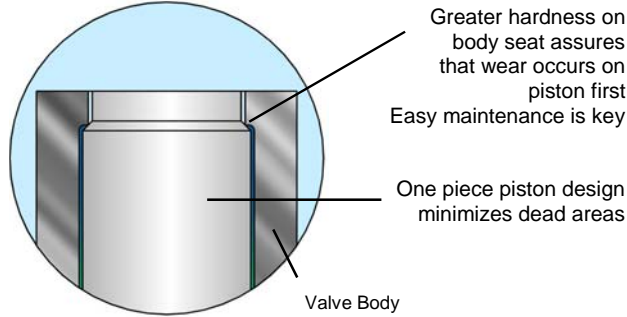

Temperature
Min: -200° C / -330° F
Max: 815° C / 1500° F
Pressure
Max: 630 bar / 9000 psig

M-Control- The **M-Control** system provides customized flow characteristics to regulate a specific laminar flow with high viscosity. The system uses a piston with a specific shape to control flow and/or pressure. **M-Control** uses the specific sealing features of the **M seal** system.

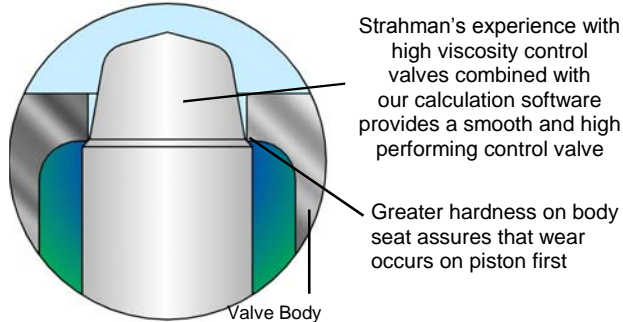

Temperature
Min: -200° C / -330° F
Max: 815° C / 1500° F
Pressure
Max: 630 bar / 9000 psig

Dual Seal- The **Dual Seal** is a unique double sealing system that works like a piston operating within a cylindrical seat. Unlike other designs, the secondary resilient seal ring is mounted on the piston and will expand after metal to metal contact of the primary seat ring. The design provides a true metal to metal seal in case of resilient seat failure.

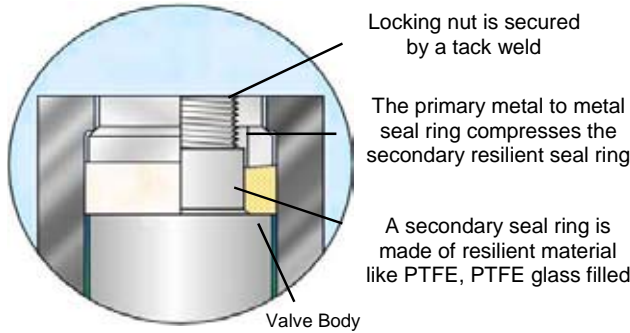

Temperature
Min: -50° C / -60° F
Max: 200° C / 450° F
Pressure
Max: 250 bar / 3550 psig & full vacuum

SEALING SYSTEMS DISC VALVES

M Seal- This sealing system offers a wide range of material combinations selected to create a differential hardness between body and plunger seat. The maintenance friendly design of the **M Seal** system provides long & reliable valve performance and is suitable for almost all process conditions.

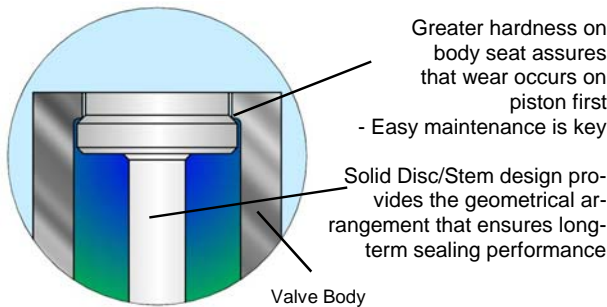

Temperature
Min: -200° C / -330° F
Max: 815° C / 1500° F
Pressure
Max: 630 bar / 9000 psig

M Ring Seal- The **M Ring Seal** is also based on a differential hardness between the body and the piston surface. The replaceable metallic seal ring made of aluminum, nickel or titanium provides excellent sealing performance especially in applications that combine full vacuum and temperatures above 200° C.

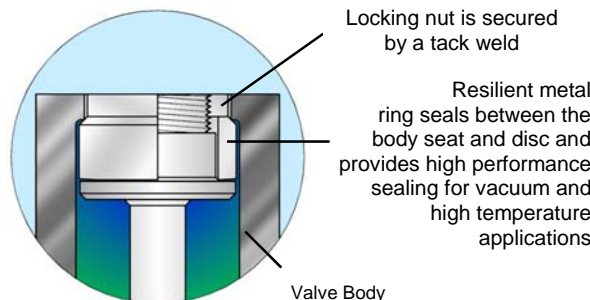

Temperature
Min: -200° C / -330° F
Max: 450° C / 840° F
Pressure
Max: 250 bar / 3550 psig & full vacuum

PACKING DEFINITION

Typical Packing Materials:

- PTFE
- PTFE / Aramide Braid
- Carbon / Graphite Braid
- Graphite Braid
- PTFE / Aramide Braid + Graphite
- Lamellar + Expanded Graphite
- Pure Graphite

Live loaded packing arrangement minimizes maintenance

Back seat arrangement is standard on this valve

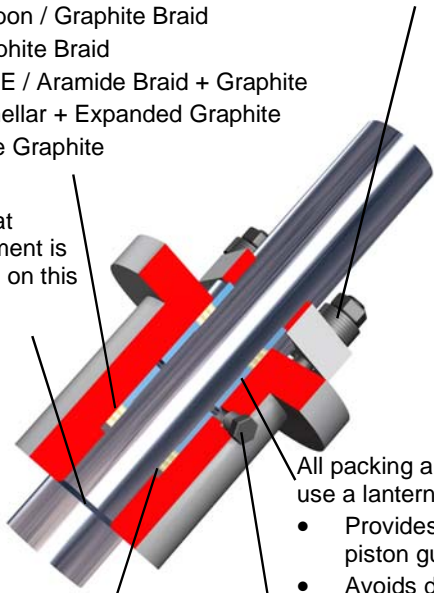

Bottom ring material is selected with a differential hardness from the piston to prevent piston damage

All packing arrangements use a lantern ring that:

- Provides better stem piston guiding
- Avoids dead space in body cavities

Optional 1/4 inch NPTF can be used for leak detection or inert gas injection to avoid leakage to atmosphere by creating an over pressure

STANDARD BODY GASKET RANGE

- PTFE
- Aramide / Nitrile
- Carbon / Aramide
- Laminated Graphite
- Laminated Graphite / 316
- Spiral Wound 316L / PTFE
- Spiral Wound 316L / Graphite
- Spiral Wound 321 / Graphite
- Spiral Wound Inconel / Graphite
- Spiral Wound Titanium / Graphite
- Welded Lips

JACKET CONNECTIONS

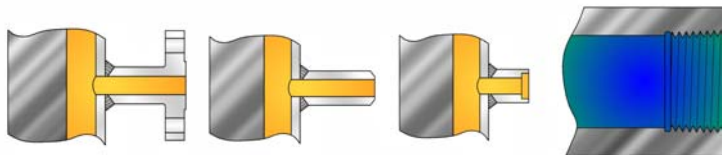

Flanges
ANSI, DIN, JIS

Butt Weld

Socket
Weld, NPT

Threaded
connections
NPT & BSP

VACUUM HOOD

For valves on full vacuum service Strahman offers a special **vacuum package** that maintains tightness to atmosphere. Valves with this package are usually equipped with an **M Ring Seal** design as process sealing. The system uses a replaceable aluminium or nickel seal ring and provides high vacuum performance. This special **vacuum package** provides zero leakage between atmosphere and process.

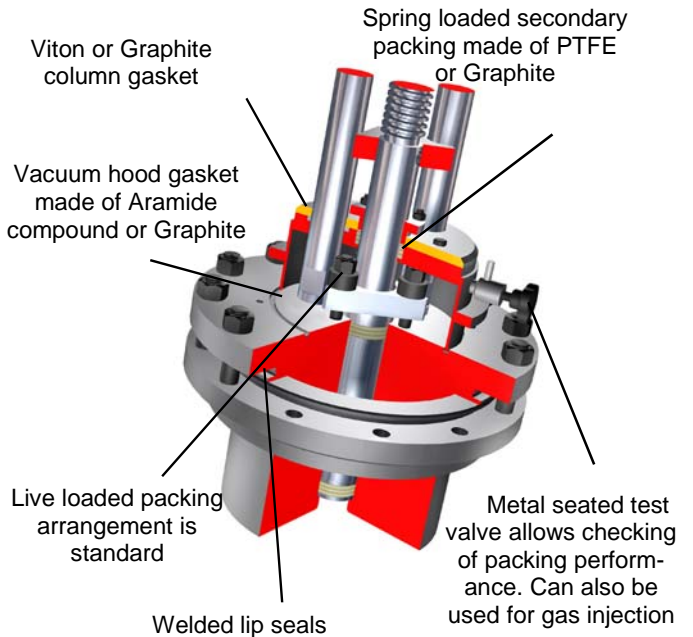

Valve Coding System

I P Y M W J

I In-Line Disc & Piston Valve	P Piston D Disc A Accessories	Y Y Pattern A Angle \$ Special	M M Seal C M Control D Dual Seal R M Ring Seal	F Flanged W Butt Weld O Over-sized Flange G Graylock \$ Special	J Jacketed - Non-Jacketed
--------------------------------------	--	---	---	--	-------------------------------------

TECHNICAL & GENERAL INFORMATION

Design Code & Construction

- Design standard compliant with ASME B16.34
- International standards include ANSI, DIN, JIS, API etc.
- Wide range of material selections including carbon steel / stainless steel / Titanium / Hastelloy / Duplex / Monel / Tantalum / Zirconium
- Fabricated, cast, forged and bar stock designs
- Combinations of fabricated, sand and investment casings, and bar stock available

Surface Finish

- For polymer applications, Strahman recommends a surface facing of 300 (Ra 0.4) for all parts in contact with the medium

Quality assurance & testing

- ISO 9001 compliant
- TUV / HPO / TA Luft
- PED / ATEX / CE marking
- Standard testing procedures

LINE & BRANCH CONNECTIONS



Flanges
ANSI, DIN, JIS



Heated
Flanges

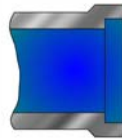

Socket
Weld

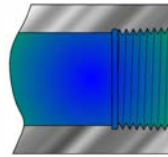

Threaded
connections
NPT & BSP



Butt
Weld

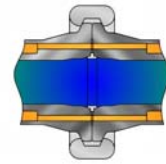

Fast Bolting Union
Graylock Securamax

ACTUATION OPTIONS



Hand Wheel



Bevel Gear



Electric Actuator



Air Motor



Double or single
acting Air Cylinder



Double or single acting Air
Cylinder with Safety Hand Wheel

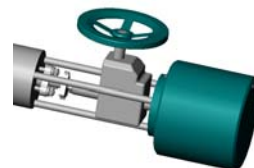

Double or single acting Air
Cylinder with side mounted
Safety Hand Wheel



Hydraulic
Cylinder

The Strahman family of products include:

SAMPLING VALVES

Strahman has a full line of sampling valves that produce live samples without exception. Our sampling valves unique design prevent failure caused by sediment or clogging.

DRAIN VALVES

Strahman Drain Valves are designed to prevent clogging. They are ideal for use in liquid and gas service or with slurries, polymers, and high viscosity fluids that tend to solidify at room temperature.

WASH DOWN EQUIPMENT

Strahman offers a full line of mixing units, hose stations, hoses, nozzles and wash down accessories. Our wash down line is designed for industrial use and is used in a wide variety of industries including food, beverage, pharmaceutical, chemical and other applications.

LINE BLINDS

Strahman Line Blinds provide zero leakage down stream and total isolation on process pipelines, vessels, and maritime applications. No pipeline movement is required when blind position is changed.

Please contact your local Strahman representative for further details
or
visit our website : www.strahmanvalves.com



Corporate Headquarters:

Strahman Valves, Inc. 2801 Baglyos Circle, Bethlehem, PA 18020
Tel: 484. 893.5080 • Fax: 484.893.5099

Strahman France:

Savoie Hexapole, F-73420, Mery, France
Tel: + 33 4 79 35 78 00 • Fax: + 33 4 79 35 78 20

Strahman German Office

Zum Schwarzhof 14, 77704, Oberkirch, Germany
Tel: +49 (0) 7802 7037879 • Fax: +49 (0) 7802 7037889

ISO 9001 Certified

Last Updated: August 25, 2009