

# Tubular Diaphragm Pumps

## Special Application Pump

Neptune Series 500 tubular diaphragm pumps are engineered for viscous fluids up to 20,000 cP and for medium slurries up to 10% solids.

## Design Features/Benefits

- No-clog design. Straight-thru flow pattern eliminates pockets where slurries can settle.
- Easily handles high viscosity liquids.
- Double diaphragm is standard.
- Capacities to 80 gph (302 lph).
- Control options include electric or pneumatic stroke control and variable speed drives.
- Standard units with double ball suction and discharge valves. Single ball suction valve is optional.
- Variable Oil By-pass™ stroke adjustment mechanism provides better valve performance than variable linkage designs. (See Bulletin DP-1100 for details on "How It Works".)
- Viton elastomer withstands most chemicals.
- Elastomer memory and tube shape reduce NPSH requirements, allow more viscous fluids to be pumped.
- Spring-loaded discharge. External back pressure valve is not required.

**Neptune**  
A DOVER COMPANY

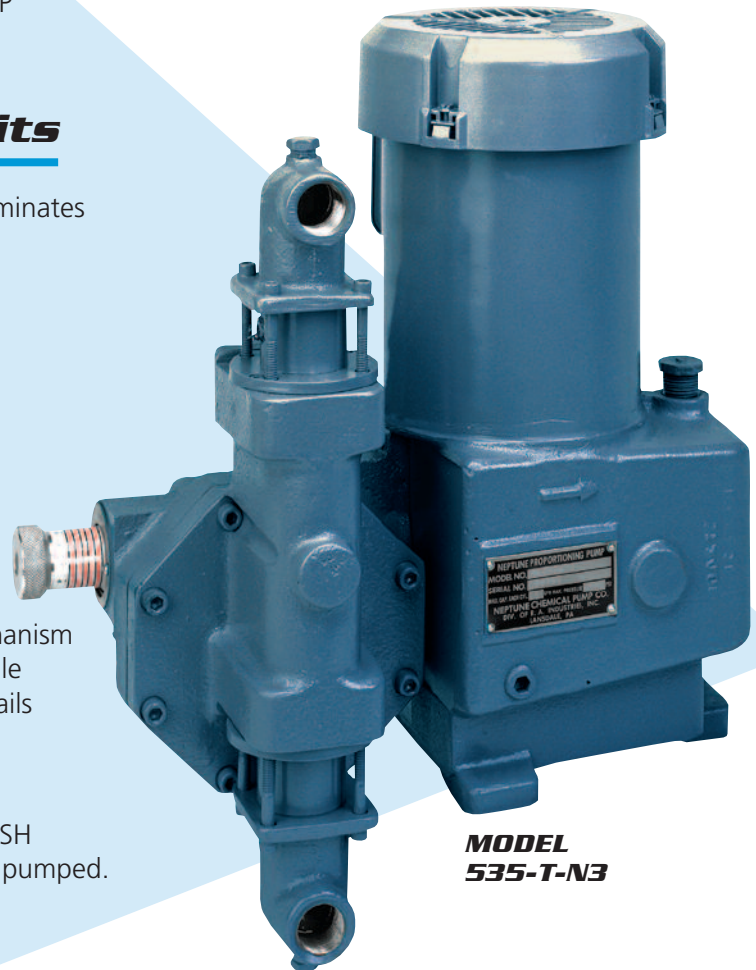

**MODEL  
535-T-N3**

### CUTAWAY VIEW

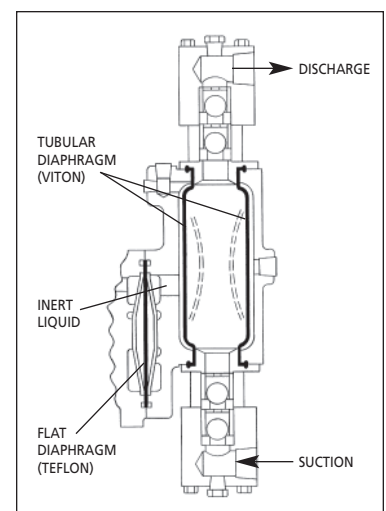

## Materials of Construction

| CODE | HEAD  | VALVE BODY | VALVE CHECK | DIAPHRAGM |
|------|-------|------------|-------------|-----------|
| N3   | 316SS | 316SS      | 316SS       | Viton     |
| N7   | 316SS | 316SS      | *           | Viton     |

\*Special slurry construction features—soft ball checks.

# Series 500 Tubular Diaphragm Pumps

## SELECTION CHART

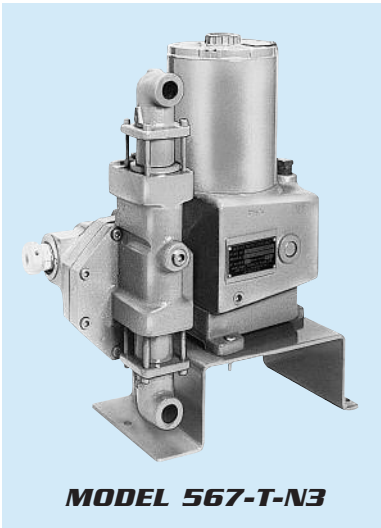

**MODEL 567-T-N3**

- Viton tube and O-rings are standard (*EPDM is available*).
- Gearbox, drive train and motor options are identical to Series 500 "dia-PUMP."

## DIMENSIONS

NOTE: Specifications subject to change without notice.

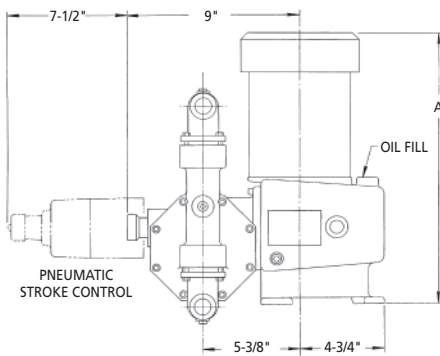

**Standard Motor All Models**

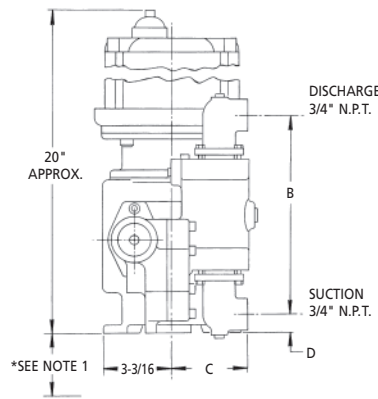

**Single Ball Models 515-547† with Explosion-Proof Motor**

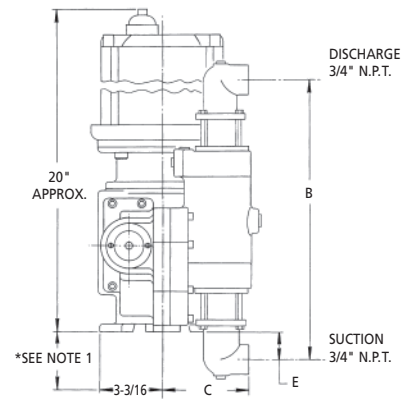

**Single Ball Models 562-567† Double Ball All Models**

| MODELS         |       | A      | B           | B           | C     | D           | E           | E           |
|----------------|-------|--------|-------------|-------------|-------|-------------|-------------|-------------|
|                |       |        | SINGLE BALL | DOUBLE BALL |       | SINGLE BALL | SINGLE BALL | DOUBLE BALL |
| 515-T TO 547-T | N3/N7 | 14-1/8 | 9-3/8       | 11-3/4      | 3-1/2 | 1/2         | —           | 1/4         |
| 562-T TO 567-T | N3/N7 | 14-3/8 | 11-3/8      | 14          | 4-1/4 | —           | 1/8         | 1-1/2       |

\*NOTE 1: All pumps supplied on 4-in. riser base.

†Double ball is standard.

### MODELS 515-547

(Standard Motor: 1/3 HP-single phase-115VAC-60 cycles-TEFC)

| MODEL NUMBER           | MATERIALS OF CONSTRUCTION | CAPACITY GPH (LPH) @ 100 PSI | MAXIMUM PRESSURE PSI (KG/CM <sup>2</sup> ) | PISTON DIAMETER | STROKES PER MINUTE | SHIPPING WEIGHT LBS. |
|------------------------|---------------------------|------------------------------|--|-----------------|--------------------|----------------------|
| 515-T-N3<br>515-T-N7   | 316SS<br>316SS            | 3.0<br>(11.3)                | 300 (22)<br>100 (8)                        | 0.500           | 117                | 80                   |
| 520-T-N3<br>520-T-N7   | 316SS<br>316SS            | 2.0<br>(7.5)                 | 300 (22)<br>100 (8)                        | 0.687           | 37                 | 80                   |
| 522-T-N3<br>522-T-N7   | 316SS<br>316SS            | 4.0<br>(15.1)                | 300 (22)<br>100 (8)                        | 0.687           | 72                 | 80                   |
| 525-T-N3<br>525-T-N7   | 316SS<br>316SS            | 7.0<br>(26.5)                | 300 (22)<br>100 (8)                        | 0.687           | 117                | 80                   |
| 530-T-N3<br>530-T-N7   | 316SS<br>316SS            | 5.5<br>(20.8)                | 300 (22)<br>100 (8)                        | 1.062           | 37                 | 80                   |
| 532-T-N3<br>532-T-N7   | 316SS<br>316SS            | 11.0<br>(41.6)               | 300 (22)<br>100 (8)                        | 1.062           | 72                 | 80                   |
| 535-T-N3<br>535-T-N7   | 316SS<br>316SS            | 18.0<br>(68.0)               | 300 (22)<br>100 (8)                        | 1.062           | 117                | 80                   |
| 547-T-N3*<br>547-T-N7* | 316SS<br>316SS            | 30.0<br>(113.0)              | 200 (15)<br>100 (8)                        | 1.062           | 144                | 80                   |

\*These models furnished with 1/2 HP motor.

### MODELS 562-567 (Standard Motor: 1/2 HP-single phase-115VAC-60 cycles-TEFC-Capacitor)

| MODEL NUMBER         | MATERIALS OF CONSTRUCTION | CAPACITY GPH (LPH) @ 100 PSI | MAXIMUM PRESSURE PSI (KG/CM <sup>2</sup> ) | PISTON DIAMETER | STROKES PER MINUTE | SHIPPING WEIGHT LBS. |
|----------------------|---------------------------|------------------------------|--|-----------------|--------------------|----------------------|
| 562-T-N3<br>562-T-N7 | 316SS<br>316SS            | 40.0<br>(151.0)              | 175 (13)<br>100 (8)                        | 2.0             | 72                 | 95                   |
| 565-T-N3<br>565-T-N7 | 316SS<br>316SS            | 65.0<br>(246.0)              | 175 (13)<br>100 (8)                        | 2.0             | 117                | 95                   |
| 567-T-N3<br>567-T-N7 | 316SS<br>316SS            | 80.0<br>(302.0)              | 175 (13)<br>100 (8)                        | 2.0             | 144                | 95                   |



P.O. Box 247 • Lansdale, PA 19446-0247  
 Tel: 215-699-8700 • Fax: 215-699-0370  
 Toll-Free Tel: 1-888-3NEPTUNE (1-888-363-7886)  
 Toll-Free Fax: 1-800-255-4017  
 Web Site: <http://www.neptune1.com>  
 E-mail: [pump@neptune1.com](mailto:pump@neptune1.com)

SOLD BY: **G&W Industrial Sales**  
 915 Emerson Avenue  
 Parkersburg, WV 26104  
 304-422-4755  
[mail@gwindustrial.com](mailto:mail@gwindustrial.com)

